



Secure & Flexible Tablet Enclosure



**FleX-7™
and
FleX-10™**

TABlock™ Series features...

- Discreet, secure tubular-keyed lock provides maximum asset protection and prevents unauthorized use.
- Patent-pending **EZ-FleX™** spring-loaded mechanism adapts to most tablets affording cross functionality to the ever-changing tablet hardware.
- **Swivel-MAX™** technology allows 360° rotation for portrait or landscape orientation and optimized viewing angle.
- Rugged and lightweight aluminum structure is radio transparent for Wi-Fi, Bluetooth and 4G-LTE friendly.
- Built-in 3.5mm audio port for most credit card readers, external speakers, or any application requiring the headphone jack.
- Convenient design facilitates installation and maintenance access.
- Mounts to a counter, cash drawer, wall or any flat surface for versatile installation.



Also available in
red and white



**FleX-7™ and
FleX-10™
Enclosure
Model Features**
(front view)

Lightweight aluminum construction



Built-in audio port extension

Bracket to stabilize credit card readers

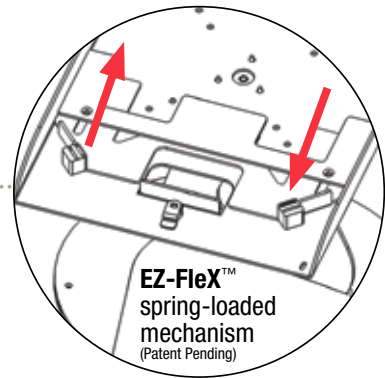

Optional custom brand imprint available with minimum order quantities

Tamper-proof cable tie opening

**FleX-7™ and
FleX-10™
Enclosure
Model Features**
(back view)

Access to power cords

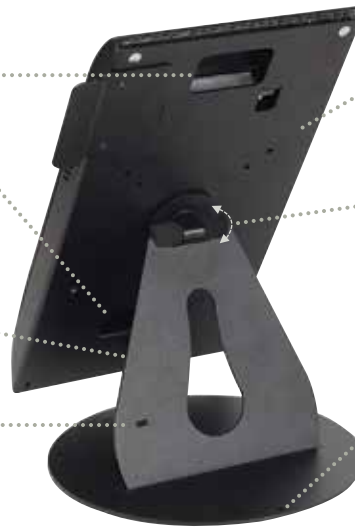

Convenient hinge allows easy open for installation and maintenance access

VESA mounting pattern (75mm & 100mm)

Discreet tubular-keyed lock

Swivel-MAX™ technology allows 360° rotation for optimized viewing angle and orientation

Kensington® security slot

Flat surface mounting holes (Installation template included)

RETAIL

CUSTOMER ENGAGEMENT

HOSPITALITY

INDUSTRIAL

HEALTHCARE



	FleX-7™	FleX-10™
DESCRIPTION	TABLock Enclosure for 7-8" Tablets	TABLock Enclosure for 9-10" Tablets
PART NUMBERS	MMF-TE0811-04 (Black) Case and Stand MMF-TE0811-07 (Red) Case and Stand MMF-TE0811-06 (White) Case and Stand MMF-TE0811A-04 (Black) Case Only	MMF-TE1011-04 (Black) Case and Stand MMF-TE1011-07 (Red) Case and Stand MMF-TE1011-06 (White) Case and Stand MMF-TE1011A-04 (Black) Case Only
TABLETS SUPPORTED (Tablets not included)	Apple iPad® Mini Samsung Galaxy Note® 8.0 Samsung Galaxy Tab® 2 7.0 Nexus®/Asus® 7" Kindle Fire® HDX 8.9"	Apple iPad® Air Apple iPad® 2 Apple iPad® (Gen 3 & 4) Nexus®/Asus® 10" Kindle Fire® HDX 10" Samsung Galaxy Note® 10.0
CREDIT CARD READERS SUPPORTED	Magtek uDynamo® Square® PayAnywhere® IDTech Shuttle® or Unimag Pro® Paypal® Here intuit GoPayment® ROAMPay® <i>NOTE: A bracket to stabilize Credit Card Readers in place is provided</i>	
DIMENSIONS (L x D x H)	6.5" x .87" x 12.62" 165 x 22 x 320 mm	8.56" x 1.0" x 13.5" 217 x 25 x 343 mm
CONSTRUCTION	Aluminum (case) Steel (stand)	
COLOR	Black (Standard) Red, White and other colors available (with minimum order of 50)	
BRANDING	Custom imprint with your brand available with minimum order quantity	
CABLE MANAGEMENT OPENINGS	Includes a 3.5mm audio port extension cord that mounts to the side panel allowing credit card readers to be plugged in. Bottom and top openings on the back side allow for power cables to be connected at all times. Additional cabling can be routed and concealed within the enclosure.	
LOCK OPTIONS	4-Pin tubular lock with 2 keys (keyed random and alike option available)	
ADDED PROTECTION	Kensington® lock opening on base Tamper-proof cable tie opening on case	
MOUNTING STAND	Round 8" diameter base with SwivelMAX™ technology for 360° rotation and maximum front to back tilt.	Round 9.5" diameter base with SwivelMAX™ technology for 360° rotation and maximum front to back tilt.

Wall Mount



(Sold separately)
P/N: 2257614104

Complete your mPOS station with the New VAL-uLine Mini Cash Drawer

PRE-ORDER NOW!
Available September 2014



- 9.62" W x 12.56" D
 - 4 Bills Slant / 4 Coins
 - Printer-driven with cable attached
- P/N: MMF-VAL10-04



www.mmfpos.com
800-769-1954